



**2009 European Patient Monitoring
Technology Leadership of the Year Award**



“We accelerate growth”

2009 European Patient Monitoring Technology Leadership of the Year Award

Award Description

The Frost & Sullivan Technology Leadership of the Year Award is bestowed upon the company that has demonstrated excellence in technology leadership within their industry. The recipient company has demonstrated technology leadership by excelling in all stages of the technology life cycle—incubation, adaptation, take-up, and maturity—to ensure a continuous flow of improvements. By innovating leading-edge concepts, the company has pioneered client applications.

Research Methodology

To choose the recipient of this Award, the analyst team tracks all emerging technologies and ongoing research and development projects within the industry. This process includes interviews with all the market participants and extensive secondary and technology research. The technologies and research projects are then compared according to customer base demands. Also considered are elements such as feasibility of product launch, likelihood of customer acceptance and acceptance rates, and estimated time to market. Competitors are then compared and ranked for relative position. The company chosen to receive the Award received the number one industry ranking.

Measurement Criteria

In addition to the methodology described above, there are specific criteria used in determining the final ranking of competitors in this industry. The recipient of this Award has excelled based on one or more of the following criteria:

- Significance of the technology in the industry
- Number of competitors having similar industry technology (competitive factor)
- The technology refinement process meets changing end-user needs (addresses research and development efforts by vendors)
- Value-added technology and services to the customers
- Adoption rate by each of the industry participants (denotes responsiveness of the vendors)
- New product innovation



Frost & Sullivan presents the '2009 European Patient Monitoring Technology Leadership of the Year Award' to Mennen Medical. Mennen Medical has a diversified portfolio of patient monitoring devices. The USP (Unique selling proposition) of Mennen Medical is that the company is able to provide customized solutions that meet the specific requirements of the hospital. These solutions, irrespective of their complexity, are easily configured by Mennen Medical because of their front end (FE) bread board technology. The FE bread board technology in Mennen Medical's patient monitoring devices is the foundation of the company's success. Time and again, the FE board technology is updated, bringing with it many improvised features that include efficient processing, credible results, and ensured reliability in the long run.

The CIPAM FE Board Technology

The company's latest development is the CIPAM (Configurable Isolated Physiological Acquisition Module) FE board technology which features multiple acquisition units for measuring various physiological parameters. The CIPAM board is an integral part of Mennen Medical's VitaLogik patient monitoring devices. The VitaLogik is a bed-side patient monitoring system that caters to a diversified patient crowd in a hospital setting and offers a reliable solution that ensures critical care. The device can be used in a broad spectrum of applications ranging from use in neonates to mature adults. The vital signs of patients are accurately monitored by this user-friendly device and it provides real-time clinical information. The VitaLogik is an easy-to-operate device and the vital signs information displayed on its monitor is easy to comprehend. It provides a quick return on investment, due to its low maintenance costs in the long run. By integrating the newly developed CIPAM board to the VitaLogik family, Mennen Medical is establishing a new benchmark by which patient monitoring devices will be measured.

CIPAM is a single front end acquisition board that acquires and analyzes vital signs from the patient and transfers it to the computer through a LAN (Local Area Network) setting. The 10 primary interfaces of the CIPAM board include:

- 3/5/10 Lead ECG
- Respiration
- 4 x Invasive blood pressure.
- SpO2 - Masimo/Nellcore
- Cardiac Output
- Temperature x 2
- NIBP
- EtCO2
- UIM (Universal Interface Module) x 2
- Aux channels

The data acquisition block diagram is depicted in Chart I.1 below.

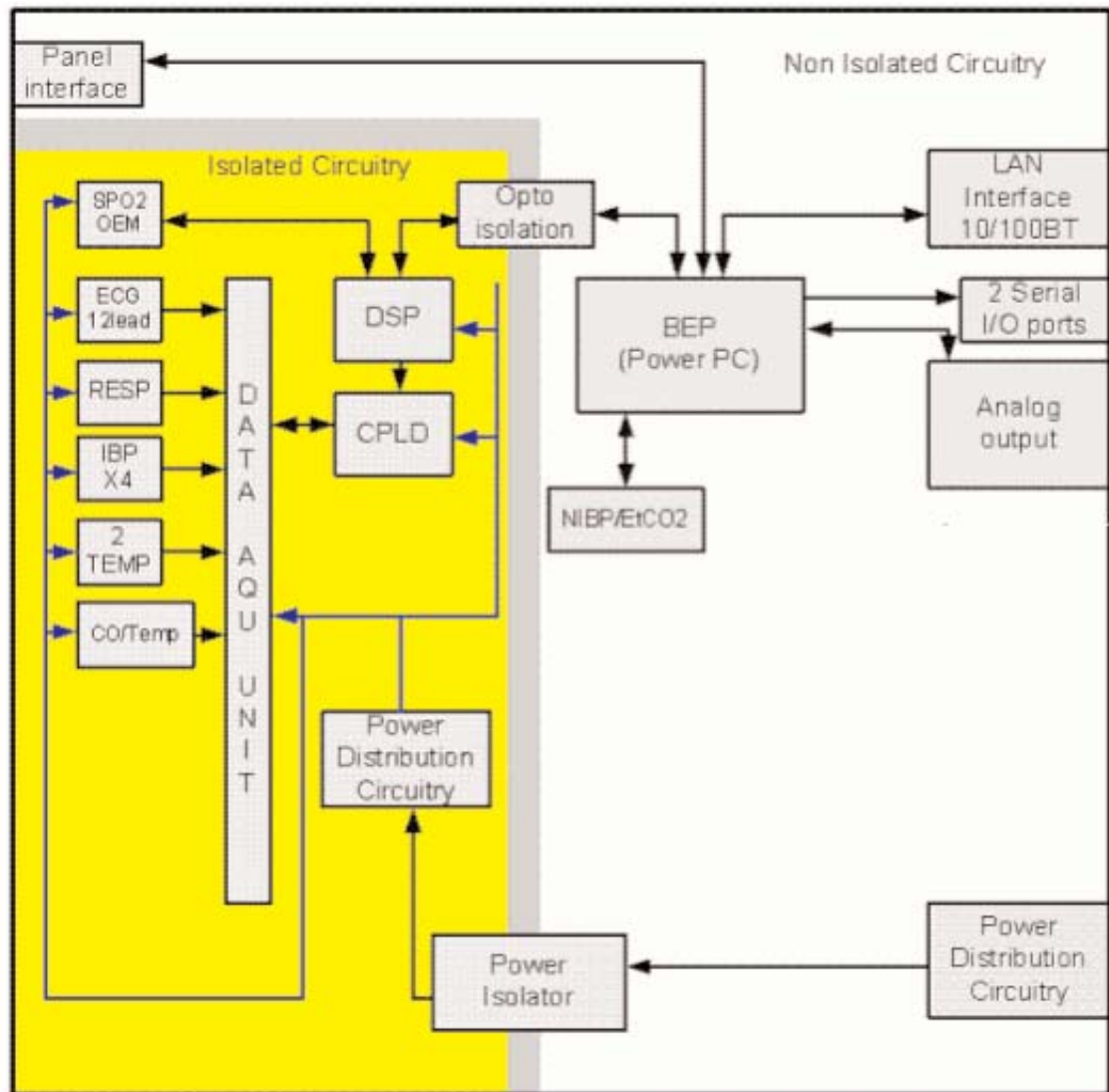

Source: Mennen Medical

Each acquisition interface is uniquely engineered in order to accurately measure patient vital signs. The intricacy of each interface is described as follows:

ECG / RSP

Monitoring the ECG produces a continuous waveform of cardiac electrical activity to enable an accurate assessment of a patient's physiological condition. One can choose 3, 5 or 10-lead electrode ECG cable set to display up to 12 selectable ECG leads.

Invasive Blood Pressure (2BP/ 4BP)

The VitaLogik connectors' panel is equipped with two invasive BP inputs that can support either 2 BP or 4 BPs with the use of a splitter cable.

CO/2Temp

The CO/2TeMP input connector support either thermal dilution Cardiac output or two temperature channels

Temperature

Temperature is detected either through the temperature input or from the CO₂Temp temperature input when Cardiac Output (CO) is not being monitored.

NIBP

Non-Invasive blood pressure is detected in the NIBP. Pressure is measured using a cuff and is derived by the oscillometric method. The cuff is automatically inflated and systolic, diastolic and mean pressures are derived as the cuff deflates. Adults and neonates may be monitored. The VitaLogik bedside monitor can be configured to take NIBP readings in one of three modes: manual, automatic and stat mode.

SPO₂ (Nellcor/Masimo)

The VitaLogik provides continuous monitoring of arterial oxygen saturation expressed as a percentage. Moment-to-moment variations in capillary filling are presented as a continuous pulse waveform. The pulse rate is derived from the pulse waveform.

EtCO₂

The End Tidal CO₂ (EtCO₂) input together with the Oridion sidestream (CO₂ control) sensor provides CO₂ measurement data to the Main Processor Unit (MPU) through the connectors' panel. In the VitaLogik's End Tidal CO₂ (EtCO₂) Microstream, input is intended for use with both intubated and non-intubated patients. The input uses real-time data to calculate and display the numerical values for End-tidal carbon dioxide (EtCO₂), inspired carbon dioxide (inCO₂) and Respiration rate.

In traditional bread board designs, the vital signs are acquired by having a separate module for each of the vital signs. With CIPAM, all the vital signs acquiring modules are technologically integrated. This technology serves as the foundation to Mennen Medicals' bed-side patient monitoring devices such as the VitaLogik 4000/4500/5000/5500. It is also used in the CathLab FE in the cardiac and peripheral catheterization room. Other advantages include its requirement of only one isolation boundary and power supply. CIPAM is also available as an OEM (Original Equipment by Manufacturer) because its application can be used by any other product that requires signal acquisition and integration (such as patient monitoring devices and anaesthesia equipments from other manufacturers).

Conclusion

The CIPAM board technology – thanks to its versatility and simultaneous applications could be a new benchmark by which patient monitoring devices from competitors may be measured. This unique technology allows Mennen Medical to use the same board for all the product range being Patient Monitors, Hemodynamic Monitoring and Angiographic Monitoring Systems.

Its precise results, long term reliability, low maintenance costs and performance credibility make it the worthy recipient of the '2009 European Patient Monitoring Technology Leadership of the Year Award'.

About Best Practices

Frost & Sullivan Best Practices Awards recognize companies in a variety of regional and global markets for demonstrating outstanding achievement and superior performance in areas such as leadership, technological innovation, customer service, and strategic product development. Industry analysts compare market participants and measure performance through in-depth interviews, analysis, and extensive secondary research in order to identify best practices in the industry.



About Frost & Sullivan

Frost & Sullivan, the Growth Partnership Company, partners with clients to accelerate their growth. The company's TEAM Research, Growth Consulting and Growth Team Membership empower clients to create a growth-focused culture that generates, evaluates and implements effective growth strategies. Frost & Sullivan employs over 45 years of experience in partnering with Global 1000 companies, emerging businesses and the investment community from more than 30 offices on six continents. For more information about Frost & Sullivan's Growth Partnerships, visit <http://www.frost.com>.

Jasmine Malone
Frost & Sullivan
DDI: +44.207.915.7867
Email: jasmine.malone@frost.com
www.frost.com

Lenny Deitch
Mennen Medical Ltd
DDI: +972 8932 3333
Email: lenny_de@mimi.co.il
www.mennenmedical.com